

ELEKTRICKÉ LANOVÉ KLADKOSTROJE STACIONÁRNÍ  
 TYP GHF, GHM 6300,8000,10000,12500-1/1,-2/1,-4/1  
 NOSNOST 1600 – 12500 kg.

ELECTRIC WIRE ROPE STATIONARY HOISTS  
 TYPE GHF, GHM 6300,8000,10000,12500-1/1,-2/1,-4/1  
 LIFTING CAPACITIES 1600 – 12500 kg.

ЭЛЕКТРИЧЕСКИЕ КАНАТНЫЕ ТЕЛЬФЕРЫ СТАЦИОНАРНЫЕ  
 ТИП GHF, GHM 6300,8000,10000,12500-1/1,-2/1,-4/1  
 ГРУЗОПОДЪЕМНОСТЬ 1600 – 12500 кг.

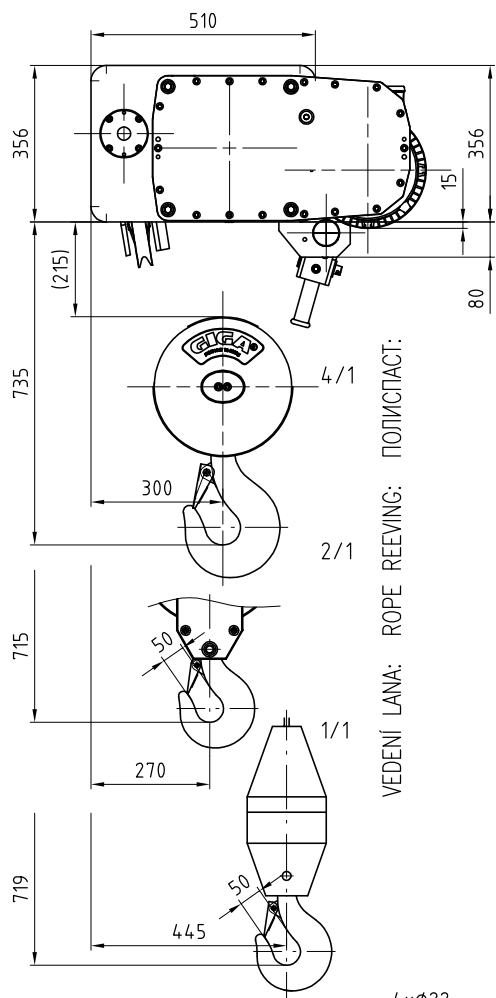

VEDENÍ LANA: ROPE REEVING: ПОЛИСПАСТ:

POHLED P  
 VIEW P  
 ВИД P

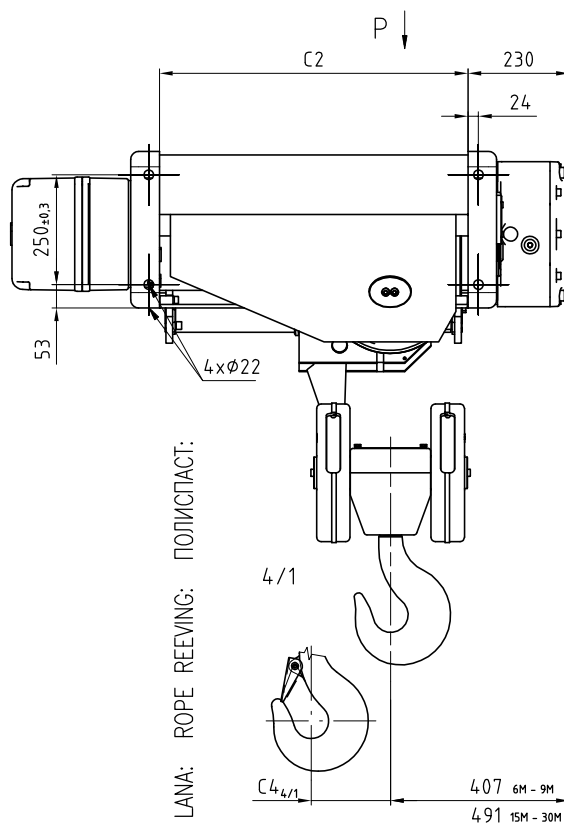

VEDENÍ LANA: ROPE REEVING: ПОЛИСПАСТ:

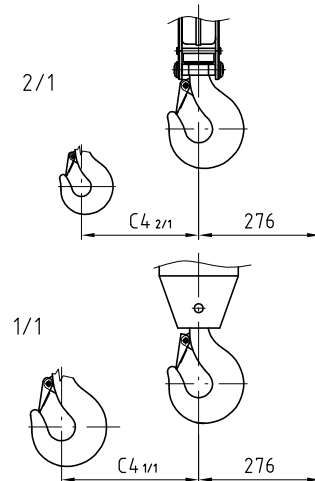
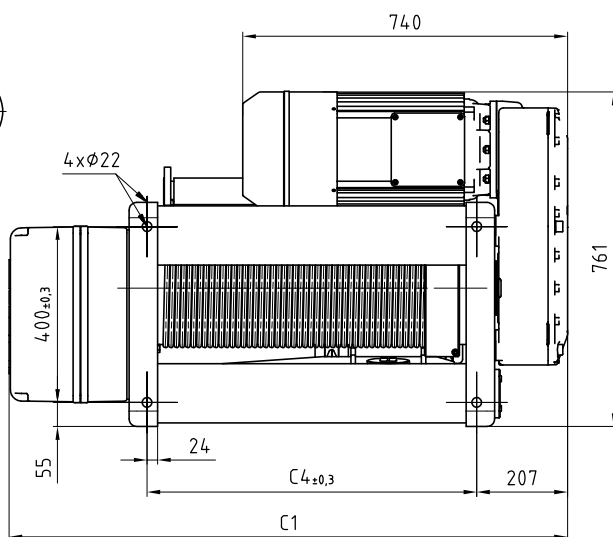

LANO  $\phi$  11mm / ROPE  $\phi$  11mm / КАНАТ  $\phi$  11мм

TYP/TYPE/ТИП		6M		9M		12M		15M		18M		21M		24M		27M		30M												
C1	C3	1107	560	1297	750	1487	940	1677	1130	1867	1320	2057	1510	2247	1700	2437	1890	2627	2080											
C2	C4 <sub>1/1</sub>	512	404	702	594	892	748	1082	974	1272	1164	1462	1354	1652	1544	1842	1734	2032	1924											
C4 <sub>4/1</sub>	C4 <sub>2/1</sub>	101	202	149	297		392	245	487	293	582	341	677	389	772	437	867	485	962											
m <sub>1/1</sub>	m <sub>2/1</sub>	m <sub>1/1</sub>	[kg]	495	425	405	530	460	440		495	475	600	530	510	635	565	545	685	615	580	720	650	615	755	685	650	790	720	685